



Raritan PX3TS

The PX3TS transfer switch provides AC power to rack IT equipment from one of two AC power sources, and automatically selects which source powers the load based on power availability and quality.

This Quick Setup Guide is intended for experienced users. For detailed instructions, refer to the PX3TS transfer switch online help from the **Support page** (<http://www.raritan.com/support/>) on Raritan's website.

Note: This guide covers two types of transfer switch products -- PX3TS and PX3TS with iX7™ controller (also known as PX3TS-iX7 or iX7™). Unless otherwise specified, PX3TS refers to both PX3TS and PX3TS-iX7 product models. For major differences between the two products, see **iX7-Specific Features** (on page 9).

Safety Precautions

WARNING! Read and understand all sections in this guide before installing or operating this product. Failure to heed any of the following WARNINGS may result in electric shock, fire, personal injury and death. Prior to operating this product, the user should read the online help and specifically the warnings in the online help.

WARNING! Connect this product to an AC power source whose voltage is within the range specified on the product's nameplate.

WARNING! Connect this product to an AC power source that is current limited by a suitably rated fuse or circuit breaker in accordance with national and local electrical codes.

WARNING! Use this product in a dry location.

WARNING! Connect this product to a protective earth ground. Never use a "ground lift adaptor" between the product's plug and the wall receptacle.

What's Included

- The PX3TS device
- Bracket pack and screws
- Quick Setup Guide
- Warranty card
- Two replacement fuses for the inlet transfer switch

Note: Depending on your PX3TS' ratings, appropriate fuse types vary. You can order additional fuses from Raritan. See Technical Specifications in the Online Help for appropriate fuse types and Raritan part numbers for these fuses.

- A null-modem cable with DB9 connectors on both ends (Raritan number: 254-01-0006-00) (optional)

Front View

1U models:

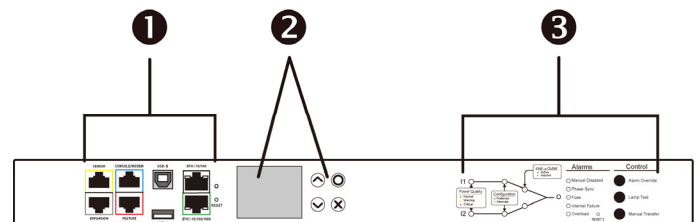

2U models:

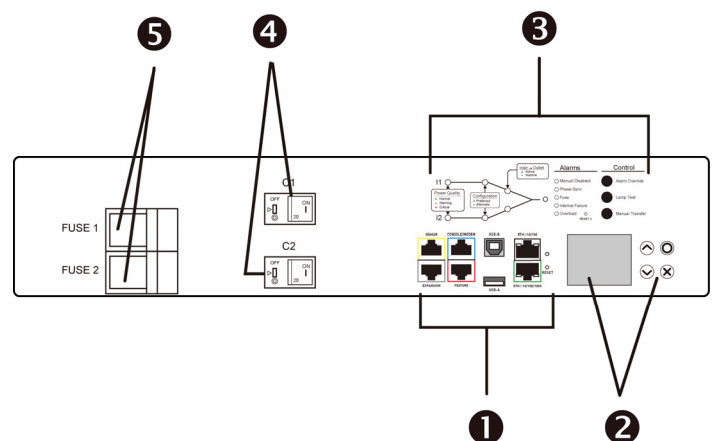

1. Connection ports (6 ports on PX3TS models or 8 ports on PX3TS-iX7 models)
2. LCD display and control buttons

3. Transfer switch indicator lamps and control buttons
4. Overcurrent protectors - one for each bank of outlets (available on some models only)
5. Fuses - one per inlet

Note: The location of fuses is model dependent. For some 2U models, fuses are located on the rear panel, but for others, fuses are located on the front panel.

Rear View

▶ 1U models:

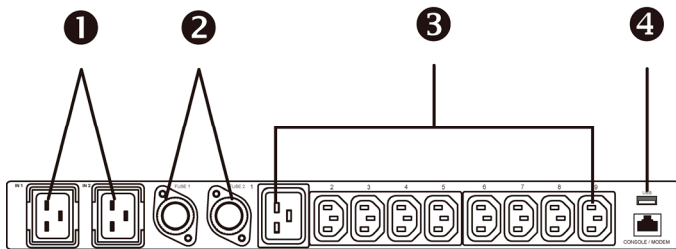

▶ 2U models:

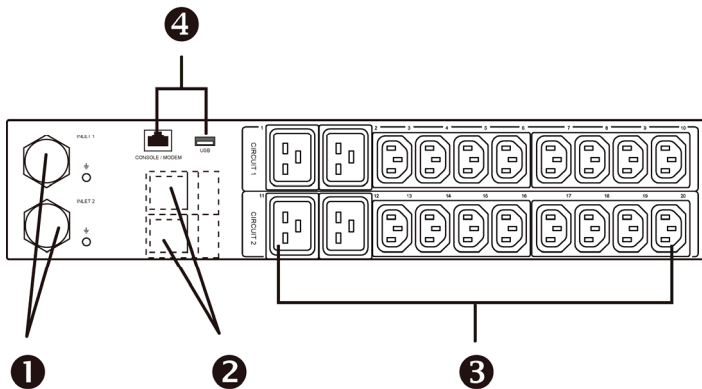

1. Inlets
2. Fuses - one per inlet

Note: The location of fuses is model dependent. For some 2U models, fuses are located on the rear panel, but for others, fuses are located on the front panel.

3. Outlets
4. Two connection ports

Mounting a PX3TS Device

Using appropriate brackets and tools, fasten the 1U or 2U PX3TS device to the rack or cabinet. The way to install a PX3TS device varies according to the device length.

▶ To mount a PX3TS device which is long:

1. Attach mounting ears and mounting brackets to each side of the PX3TS with provided screws.

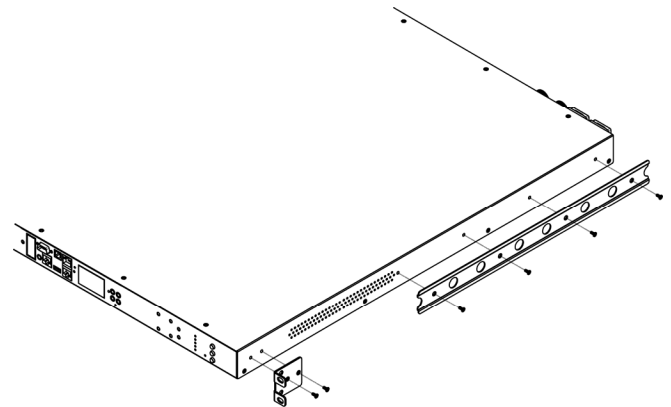

2. Adjust slide-rail assemblies to match your rack posts and fasten them to the rack using your own fasteners.

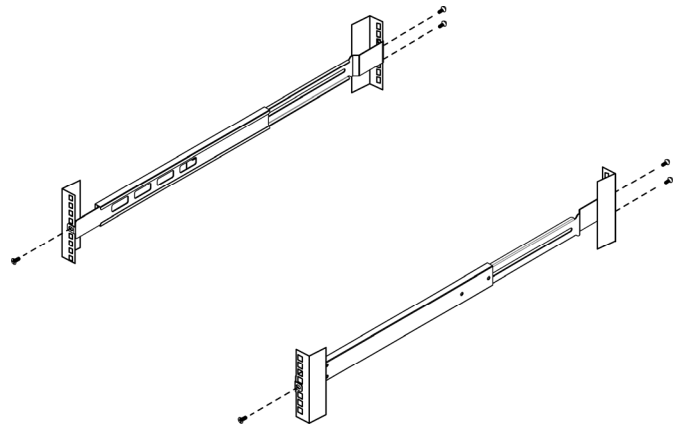

3. Line up the mounting brackets with slide-rails and push this product into rails.

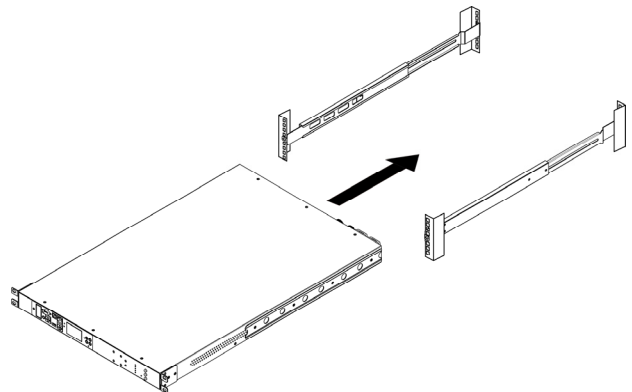

4. Fasten front mounting ears to the rack using your own fasteners.

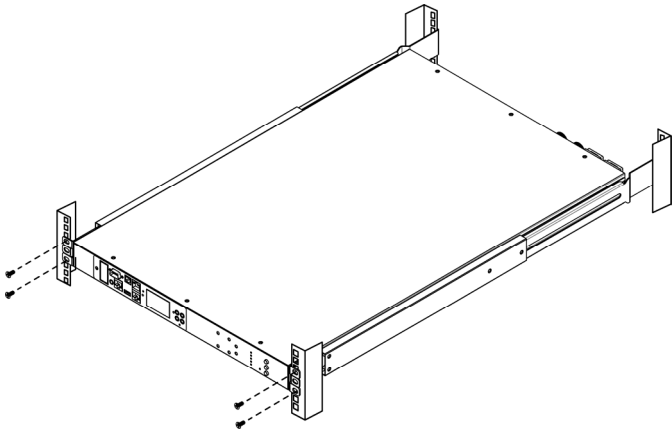

► **To mount a PX3TS device which is short:**

1. Attach a rackmount bracket to both sides of the PX3TS with the provided screws. For a 1U model, the total number and locations of screw holes are different from the following 2U diagram.

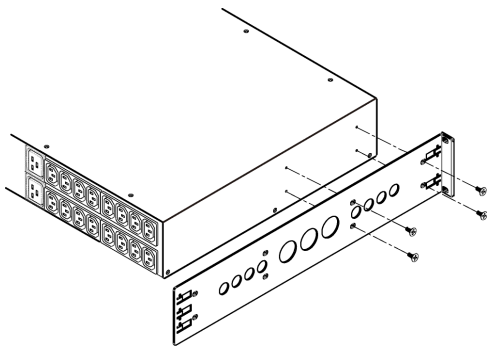

2. Insert the cable-support bar into rackmount brackets.

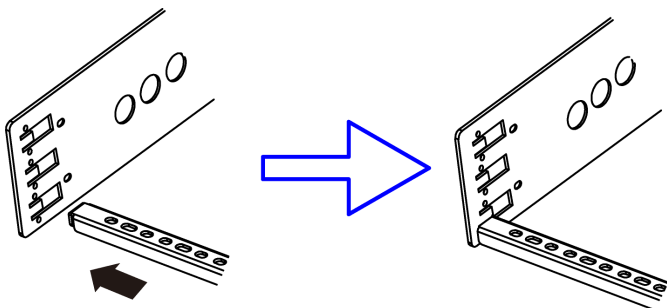

3. Secure with the provided end cap screws.

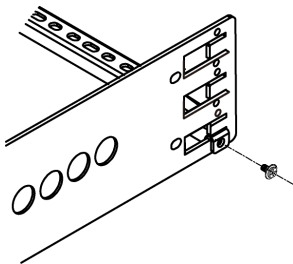

4. On a 2U model, repeat the above steps to install another cable-support bar.

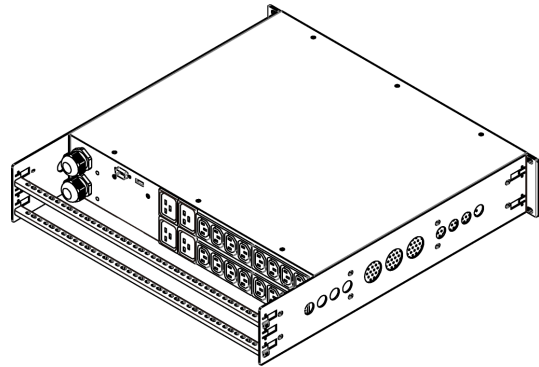

5. Fasten the rackmount brackets' ears to the rack using your own fasteners.

Inlet and Outlet Power Connections

The PX3TS connects to two different, but identically rated, branch circuits.

The PX3TS will operate when the branch circuit voltages are out of phase, but works most reliably and fastest when in phase. The front panel Phase Sync lamp lights if inlets are out of phase.

Connecting Power and Equipment

Your PX3TS may have fuses and/or circuit breakers. Verify that all are firmly seated or set to ON before connecting power.

The PX3TS inlets are labeled INLET 1 (I1) and INLET 2 (I2). INLET 1 is the factory default preferred inlet, and INLET 2 is the factory default alternate inlet.

Tip: You can switch preferred and alternate inlets if needed. See **Manual Transfer** (on page 5).

► **To make power connections:**

1. Connect PX3TS inlets to branch circuits.
2. Connect loads to PX3TS outlets.
3. Apply power to branch circuits.

Testing Indicator Lamps

Press the Lamp Test control button and visually verify that all transfer switch indicator lamps turn on. See **Control Push Buttons** (on page 5).

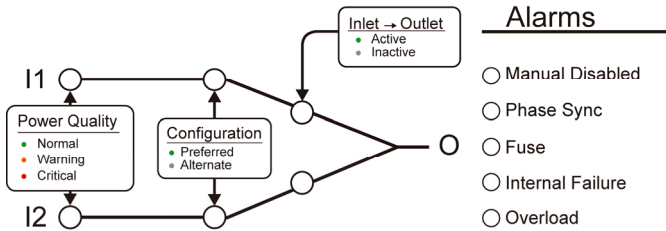

Power Quality Indicator Lamps

Inlet power quality is shown using a tricolor LED.

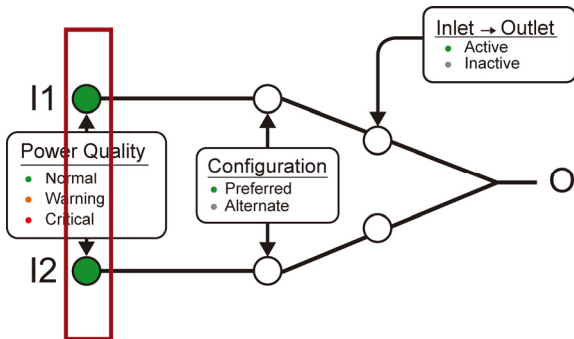

- Normal (green): Power quality (voltage and frequency) is good.
- Warning (orange): Power quality is not optimal but acceptable.
- Critical (red): Power is not available or power quality is not acceptable.

Note: See **Power Quality Setup** (on page 7) for how to configure voltage and frequency settings.

Inlet Configuration Indicator Lamps

A green LED indicates which inlet is preferred. The default is Inlet 1.

The preferred inlet powers the outlets unless its power quality goes critical. The Manual Transfer button may change the preferred inlet. See **Control Push Buttons** (on page 5).

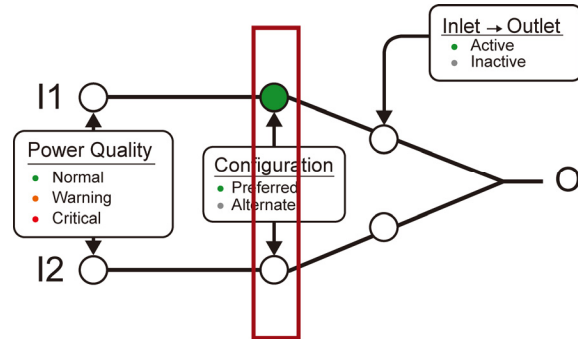

Active Inlet Indicator Lamps

A green LED indicates which inlet is powering the outlets. Only one LED is on at a time.

The Manual Transfer button transfers power to the other inlet.

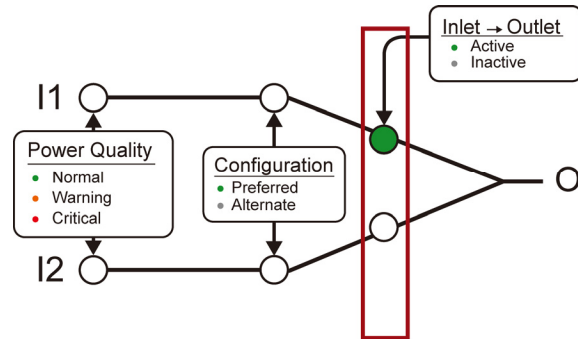

Alarm Indicator Lamps

Alarms

- Manual Disabled
- Phase Sync
- Fuse
- Internal Failure
- Overload

Lamp	Meaning
Manual Disabled	The front panel Manual Transfer button is disabled. See Control Push Buttons (on page 5).
Phase Sync	Inlets are out of phase.

Lamp	Meaning
Fuse	Blown fuse. The replacement fuse must be either the same as the Raritan-provided fuse or equivalent. To order fuses from Raritan, see Technical Specifications in the Online Help for appropriate fuse types and Raritan part numbers.
Internal Failure	Internal hardware failure. Contact Raritan technical support. The web interface contains additional indicators for specific internal failures.
Overload	Power to load is turned off due to a short circuit.

Control Push Buttons

Control



Alarm Override



Lamp Test



Manual Transfer

Button	Action taken when pressed
Alarm Override	Forces a manual transfer during an alarm condition.
Lamp Test	Turns on all transfer switch indicator lamps. Power Quality LEDs turn orange.
Manual Transfer	Transfers power to the other inlet. Newly-activated inlet becomes the preferred inlet.

Operating Modes

Normal: The preferred inlet is active while the alternate inlet is in the normal or warning state.

Non-redundant: The preferred inlet is active while the alternate inlet goes critical or loses power.

Standby: The alternate inlet is active.

Off: Neither inlet is active because of an alarm or internal failure, or because both inlets go critical. See **Manual Transfer** (on page 5) for restoring power.

Automatic Transfer

An automatic transfer to the alternate inlet occurs when the preferred inlet's power quality goes critical.

An automatic retransfer back to the preferred inlet occurs when the preferred inlet's power quality returns to normal.

Note: See **Transfer Options Setup** (on page 6) for retransfer settings.

Manual Transfer

The Manual Transfer button changes the active inlet and also sets the newly-activated inlet to be the preferred inlet.

The Manual Transfer button is disabled when an alarm lamp is active. Use this procedure to override the alarm and force a manual transfer.

1. Correct the problem in load that caused the alarm.
2. While holding down the Alarm Override button, press Manual Transfer.

Note: This procedure does not apply when the Manual Disabled or Fuse alarm lamp is turned on.

Connecting the PX3TS to Your Network

PX3TS can be connected to a wired or wireless network. For connection to a wireless network. See **Appendix B: Wireless Configuration** (on page 8).

► To make a wired connection for PX3TS:

1. Connect a standard network patch cable to the ETHERNET port on the PX3TS.
2. Connect the other end of the cable to your LAN.

► To make a wired connection for PX3TS-iX7:

- You can connect either Ethernet port of an iX7™ device to the LAN, but the "green" port labeled "ETH⑩10/100/1000" is highly recommended because it supports 1000 Mbps. Refer to the above procedure for cable connection.
- If connecting both ports to the LAN, you must connect them to two "different" subnets. If you are not sure whether the device is connected to the same or different subnets, contact your IT department.

PX3TS Configuration

Note: If your networking environment is not the DHCP IPv4 networking environment, for example, an IPv6 network, refer to **Appendix A: Configuration via a Mobile Device or PDView** (on page 7) for initial configuration.

Step 1: Display the IPv4 or IPv6 Address

The DHCP-assigned IPv4 address is available using the front panel display. Depending on the model you purchased, the front panel display is similar to either diagram below. For PX3TS-iX7 models with the new panel, you can retrieve both IPv4 and IPv6 addresses, if available.



- OR -

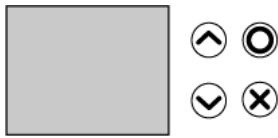







► To retrieve the "IPv4" address on PX3TS:

1. Press the MODE button to enter the Device mode, indicated by an alphabet "d" at the top left of the display.
2. The LCD display cycles between the four octets of the IPv4 address, indicated by "i4" at the upper right corner of the display.

For example, 192.168.84.4 cycles in this sequence:
192 --> 168 --> 84 --> 4

► To retrieve the IPv4 or IPv6 address on PX3TS-iX7:

1. Press  or  to show the "Main Menu."
2. Press  or  to select "Device Info," and press .
3. Press  or  until the device's IP address is displayed.

Note: If your network only supports IPv6 or DHCP is unavailable, the IP address must be configured through an USB connection to a mobile device. See **Appendix A: Configuration via a Mobile Device or PDView** (on page 7).

Step 2: Log in to the PX3TS Web Interface

1. Open a web browser and type the IP address of PX3TS.
 - If the link-local addressing has been enabled, you can type *pdu.local* instead of an IP address. See Appendix A: Configuration via a Connected Computer.

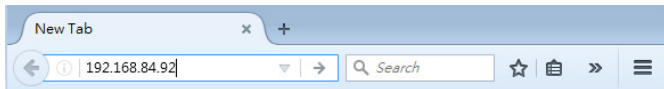

2. Accept any security warnings that may appear.
3. Type the default user credentials and click Login.

- User name: admin
- Password: raritan

4. When prompted to change the password, change or ignore it.
 - To change it, type the new password and click Ok.
 - To ignore it for this time only, click Not Now.
 - To ignore it permanently, select "Do not ask again" and click Not Now.

Step 3: PX3TS Web Configuration Overview

1. In the left menu, click Transfer Switch.

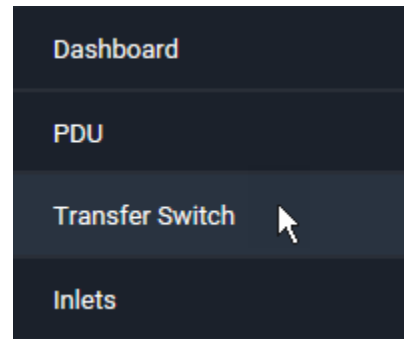

2. Click Edit Settings to configure the transfer options.
3. Click Edit Power Quality Parameters to configure power quality.

Settings	2	3
	Edit Settings Edit Power Quality Parameters	
Name		
Allow Front Panel Transfer	yes	
Automatic Retransfer	Only if phases are in sync	
Retransfer Wait Time	15 seconds	

Transfer Options Setup

1. (Optional) Assign a name to the inlet transfer switch if wanted.
2. Enable/disable the front panel Manual Transfer button.
3. Enable/disable automatic retransfer, and determine whether to perform retransfer when inlets are out of phase. Retransfer is the transfer back to normal operation when preferred inlet power is restored.

- Enter the time (seconds) preferred inlet power must be in the normal state before retransfer occurs.

Power Quality Setup

Inlet power quality state (normal/warning/critical) is derived from the inlet's voltage and frequency quality - whichever is lower. If voltage or frequency is critical, power quality is critical. If either is warning, quality is warning. When both are normal, power quality is normal.

PX3TS transfers to standby operation when preferred inlet power quality goes critical and retransfers to normal operation when power quality returns to normal. The warning state does not cause transfers and is intended as an early warning indication of a possible problem.

When quality goes from better to worse, the state change is said to assert. You configure how long the quality must remain in the worse state before the state change actually occurs. When quality goes from worse to better, the state change is said to deassert. You configure the hysteresis - how much the quality must be better than the threshold - before the state change occurs.

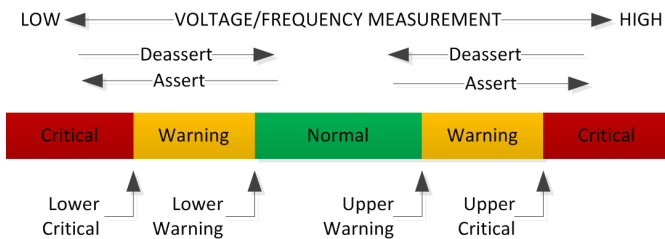

Voltage and frequency configuration is identical.

- Enter upper and lower thresholds for warning and critical.
- Enter deassertion hysteresis values.

- Enter assertion times (seconds).

Appendix A: Configuration via a Mobile Device or PDView

An iOS or Android mobile device, such as a smartphone or tablet, can function as a local display of PX3TS. Note that the Android device must support USB "On-The-Go" (OTG), or this function does not work.

Step 1: Download the "PDView" App

Raritan's app "PDView" is required for the mobile device to function as a local display. It is a free app.

► **To download PDView:**

- Visit either Apple App or Google Play Store.
 - <https://itunes.apple.com/app/raritan-pdview/id780382738>



- <https://play.google.com/store/apps/details?id=com.raritan.android.pdview>



2. Install PDView.



Step 2: Connect the Mobile Device to PX3TS

The USB cable and USB port to connect are determined by your mobile operating system.

► To connect your mobile device to PX3TS:

1. Get an appropriate USB cable for your mobile device.
 - *iOS*: Use the regular USB cable shipped with your iOS mobile device.
 - *Android*: Use an **USB OTG** adapter cable.
2. Connect the mobile device to the appropriate USB port on the PX3TS.
 - *iOS*: USB-A port.
 - *Android*: USB-B port

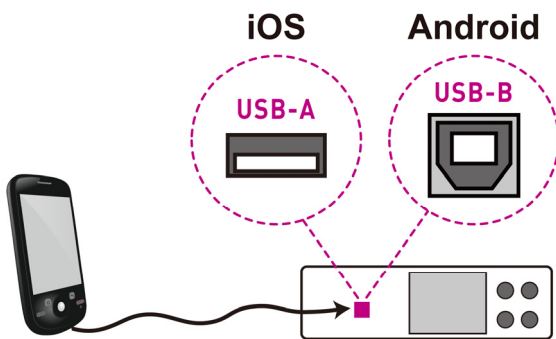

Step 3: Launch PDView

You can access the PX3TS web interface via PDView to view or change the settings.

► To access the PX3TS web interface:

1. Launch PDView on your mobile device.
2. Wait until PDView detects the connected PX3TS device and shows the word "Connected" in green.

Connected

3. If the factory-default user credentials "admin/raritan" remain unchanged, PDView automatically logs in to the PX3TS web interface.

If they have been changed, the login screen displays instead and you must enter appropriate user credentials for login.

4. (Optional) For initial login, you are prompted to change the password. See **Step 2: Log in to the PX3TS Web Interface** (on page 6).
5. Now you can view the data or change any PX3TS settings.
 - For details, refer to the user guide or online help on the Raritan website.

Appendix B: Wireless Configuration

USB Wireless LAN Adapters

The PX3TS supports the following USB Wi-Fi LAN adapters.

Wi-Fi LAN adapters	Supported 802.11 protocols
SparkLAN WUBR-508N	A/B/G/N
Proxim Orinoco 8494	A/B/G
Zyxel NWD271N	B/G
Edimax EW-7722UnD	A/B/G/N
TP-Link TL-WDN3200 v1	A/B/G/N
Raritan USB WIFI	A/B/G/N

Note: To use the Edimax EW-7722UnD or Raritan USB WIFI wireless LAN adapter to connect to an *802.11n* wireless network, the handshake timeout setting must be changed to 500 or greater, or the wireless connection will fail.

Supported Wireless LAN Configuration

If wireless networking is preferred, ensure that the wireless LAN configuration of your PX3TS matches the access point. The following is the wireless LAN configuration that the PX3TS supports.

- Network type: 802.11 A/B/G/N
- Protocol: WPA2 (RSN)
- Key management: WPA-PSK, or WPA-EAP with PEAP and MSCHAPv2 authentication
- Encryption: CCMP (AES)

Important: Supported 802.11 network protocols vary according to the wireless LAN adapter being used with the PX3TS. See *USB Wireless LAN Adapters* (on page 8).

Making a Wireless Connection

Make the PX3TS connect to a wireless network as needed.

► **To make a wireless connection:**

Do one of the following:

- Plug a supported USB wireless LAN adapter into the USB-A port on your PX3TS.
- Connect a USB hub to the USB-A port on the PX3TS. Then plug the supported USB wireless LAN adapter into the appropriate USB port on the hub.

See **USB Wireless LAN Adapters** (on page 8) for a list of supported wireless LAN adapters.

Appendix C: Other Information

RJ-45 Cap in the Feature Port (for Non-iX7 Models Only)

PX3TS models have a cap plugged into the FEATURE port when shipping out of the factory. The cap is intended to protect the port from connecting to inappropriate equipment. Remove it if needed.

Note: PX3TS-iX7 models do NOT have this cap plugged when shipping out of the factory.

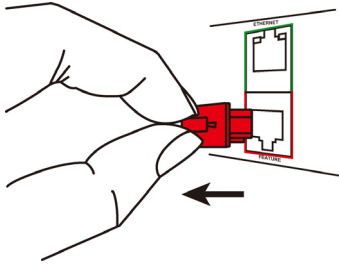

iX7-Specific Features

PX3TS with iX7™ controller supports the following significant features, which are NOT supported by non-iX7 PX3TS models.

- Dual networking with two Ethernet ports (ETH1/ETH2): Both Ethernet ports must connect to two "different" subnets. Connection to the same subnet is NOT recommended.
- Power sharing via the EXPANSION port: Power sharing ensures the continuous accessibility to the iX7™ controller when a power failure occurs on both inlets.

For more information on dual Ethernet and power sharing functionality, refer to PX3TS online help or user guide. Port locations on your iX7™ may look different from the following illustration.

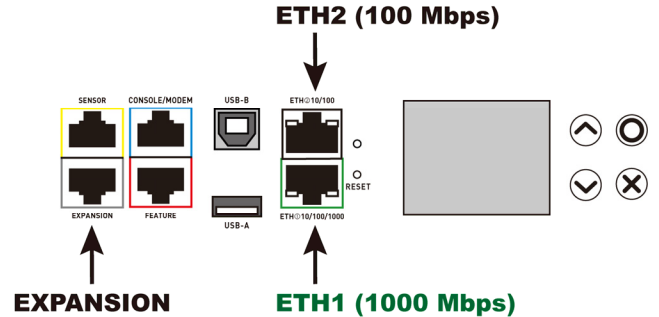

Identifying the Sensor Port

Warning: If you purchase Raritan's environmental sensor packages, make sure you connect them to the correct port on the PX3TS, or damages may be caused to the PX3TS and/or connected sensor packages.

► **How to identify the SENSOR port:**

- The correct port is labeled SENSOR.
- The SENSOR port is marked with YELLOW color, as shown below.

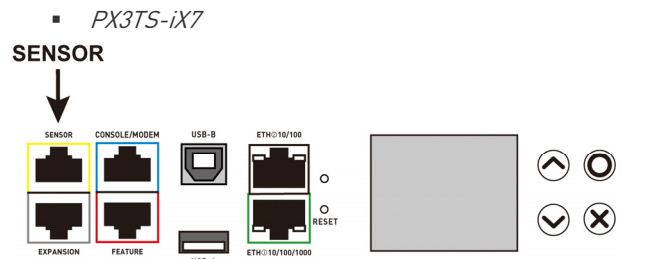
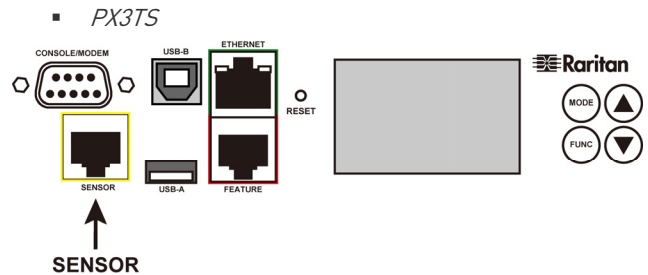

Additional Information

For more information about PX3TS and the entire Raritan product line, see Raritan's website (www.raritan.com). For technical issues, contact Raritan Technical Support. See the



Contact Support page in the Support section on Raritan's website for technical support contact information worldwide.

Raritan's products use code licensed under the GPL and LGPL. You can request a copy of the open source code. For details, see the Open Source Software Statement at (<http://www.raritan.com/about/legal-statements/open-source-software-statement/>) on Raritan's website.